

RT-F40G13-C00

40Gb/s QSFP+ PSM4 2KM Optical Transceiver

Product Features

- Four-channel full-duplex transceiver modules
- Transmission data rate up to 11.2Gbit/s per channel
- Up to 2km transmission of single mode fiber
- Low power consumption <2.5W, meet class 3
- Operating case temperature: 0 to 70°C
- 3.3V power supply voltage
- Hot Pluggable QSFP form factor
- RoHS 6 compliant
- Single MPO connector receptacle
- Built-in digital diagnostic function

Applications

- Infiniband QDR and DDR interconnects
- 40G Ethernet
- Proprietary High Speed Interconnections
- Data center

The RayOptek RT-F40G13-C00 is a Four-Channel, Pluggable, Parallel, Fiber-Optic QSFP+ Transceiver for InfiniBand QDR/DDR/SDR, 10G/8G/4G/2G fiber channel, PCIe and SAS Applications. The QSFP full-duplex optical module offers 4 independent transmit and receive channels, each capable of 11.2Gbps operation for an aggregate data rate of 40Gbps 2km using single mode fiber. These modules are designed to operate over single mode fiber systems using 1310nm DFB laser array. An optical fiber ribbon cable with an MPO/MTP™ connector can be plugged into the QSFP module receptacle. QSFP+ PSM IR4 is one kind of parallel transceiver which provides increased port density and total system cost savings.

Ordering Information

Part Number	Description
RT-F40G13-C00	QSFP+ PSM4 2km optical transceiver with full real-time digital diagnostic monitoring and pull tab

For More Information:

Wuhan RayOptek Co.,Ltd
 Address: G3-201,NewEnergy Building,No.999 Gao Xin Road, Wuhan, Hubei, China
 Phone: 0086-27-87106345 Fax: 0086-27-87106345 Email: sales@rayoptek.com

Regulatory Compliance

Feature	Standard	Performance
Electromagnetic Interference (EMI)	FCC Part 15 Class B EN 55022:2010, Class B	Compatible with standards
Electromagnetic susceptibility (EMS)	EN 55024:2010	Compatible with standards
Laser Eye Safety	FDA 21CFR 1040.10 and 1040.11 EN60950, EN (IEC) 60825-1,2	Compatible with Class I laser product

Absolute Maximum Ratings

The operation in excess of any absolute maximum ratings might cause permanent damage to this module.

Parameter	Symbol	Min	Max	Unit	Notes
Storage Temperature	T _s	-40	85	°C	
Operating Case Temperature	T _{OP}	0	70	°C	
Power Supply Voltage	V _{CC}	-0.3	3.6	V	
Relative Humidity (non-condensation)	RH	0	85	%	
Input Voltage	V _{in}	-0.3	V _{CC} +0.3	V	

Recommended Operating Conditions and Power Supply Requirements

Parameter	Symbol	Min	Typical	Max	Unit	Notes
Operating Case Temperature	T _{OP}	0		70	°C	
Power Supply Voltage	V _{CC}	3.135	3.3	3.465	V	
Power Consumption			1.7	2.5	W	
Data Rate, each Lane	DR		10.3		Gb/s	
Data Speed Tolerance	ΔDR	-100		+100	ppm	
Link Distance with G.652	D	0		2	km	

Electrical Characteristics

Parameter	Symbol	Min	Typical	Max	Unit	Notes
Differential input impedance	Z _{in}	90	100	110	ohm	
Differential Output impedance	Z _{out}	90	100	110	ohm	
Differential input voltage amplitude	ΔV _{in}	300		1100	mVp-p	
Differential output voltage amplitude	ΔV _{out}	500		800	mVp-p	
Bit Error Rate	BR			E-12		
Input Logic Level High	V _{IH}	2.0		V _{CC}	V	
Input Logic Level Low	V _{IL}	0		0.8	V	
Output Logic Level High	V _{OH}	V _{CC} -0.5		V _{CC}	V	
Output Logic Level Low	V _{OL}	0		0.4	V	

Optical Characteristics

Parameter	Symbol	Min	Typical	Max	Unit	Notes
Transmitter						
Center Wavelength	λ _C	1270	1310	1350	nm	1
RMS Spectral Width	λ _{rms}			3.5	nm	1
Average Launch Power, each lane	PAVG	-5.5	-0.5	+2.3	dBm	
Optical Modulation Amplitude (OMA)	POMA	-4.5	-0.5	+3.5	dBm	1
Difference in Launch Power between any two lanes	P _{tx,diff}			5.0	dB	
Launch Power in OMA minus Transmitter and Dispersion Penalty (TDP), each Lane	OMA-TDP	-9.7			dBm	1
Rise/Fall Time	T _r /T _f			50	ps	
Extinction Ratio	ER	3.5			dB	
Relative Intensity Noise	R _{in}			-128	dB/Hz	

Optical Return Loss Tolerance	TOL			12	dB	
Transmitter Reflectance	RT			-12	dB	
Transmitter Eye Mask Margin	EMM	10			%	2
Transmitter Eye Mask Definition {X1, X2, X3, Y1, Y2, Y3}		{0.25, 0.4, 0.45, 0.25, 0.28, 0.4}				
Average Launch Power OFF Transmitter, each Lane	Poff			-30	dBm	
Receiver						
Center Wavelength	λ C	1270	1310	1350	nm	
Damage Threshold	THd	+3			dBm	
Overload, each lane	OVL	+2.3			dBm	
Receiver Sensitivity in OMA, each Lane	SEN			-11.5	dBm	
Difference in Receive Power between any two Lanes (OMA)	Prx,diff			5.0	dB	
Signal Loss Assert Threshold	LOSA	-30			dBm	
Signal Loss Deassert Threshold	LOSD			-15	dBm	
LOS Hysteresis	LOSH	0.5		6	dB	
Optical Return Loss	ORL			-12	dBm	
Receive Electrical 3 dB upper Cutoff Frequency, each Lane	Fc			12	GHz	

Notes:

1. Transmitter wavelength, RMS spectral width and power need to meet the OMA minus TDP specs to guarantee link performance.
2. The eye diagram is tested with 1000 waveform.

Digital Diagnostic Functions

Digital diagnostics monitoring function is available on all RAYOPTEK QSFP+ PSM LR4. A 2-wire serial interface provides user to contact with module. The structure of the memory is shown in Figure 3. The memory space is arranged into a lower, single page, address space of 128 bytes and multiple upper address space pages. This structure permits timely access to addresses in the lower page, such as Interrupt Flags and Monitors. Less time critical time entries, such as serial ID information and threshold settings, are available with the Page Select function. The interface address used is A0xh and is mainly used for time critical data like interrupt handling in order to enable a one-time-read for all data related to an interrupt situation. After an interrupt, IntL, has been asserted, the host can read out the flag field to determine the affected channel and type of flag.

Parameter	Symbol	Min	Max	Unit	Notes
Temperature monitor absolute error	DMI_Temp	-3	+3	°C	Over operating temperature range
Supply voltage monitor absolute error	DMI_VCC	-0.1	+0.1	V	Over full operating range
Channel RX power monitor absolute error	DMI_RX_Ch	-3	+3	dB	1
Channel Bias current monitor	DMI_Ibias_Ch	-10%	+10%	mA	
Channel TX power monitor absolute error	DMI_TX_Ch	-3	+3	dB	1

Recommended Power Supply Filter

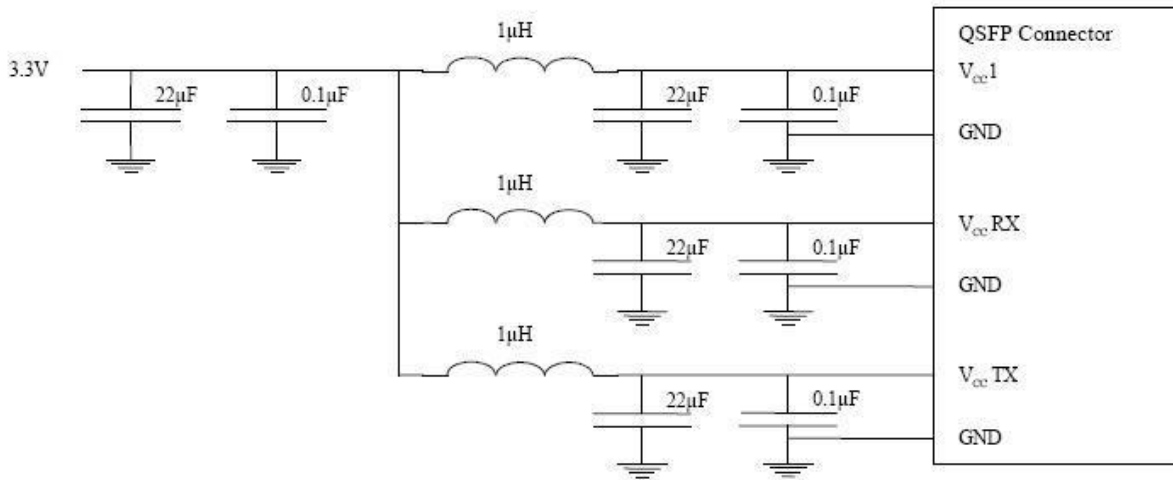

Optical Interface Lanes and Assignment

The optical interface port is a male MPO connector. The four fiber positions on the left as shown in Figure 2, with the key up, are used for the optical transmit signals (Channel 1 through 4). The fiber positions on the right are used for the optical receive signals (Channel 4 through 1). The central four fibers are physically present.

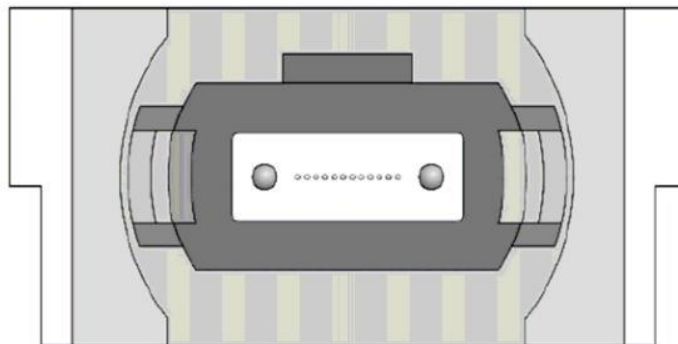

Transmit Channels: 1 2 3 4
 Unused positions: x x x x
 Receive Channels: 4 3 2 1

Mechanical Dimensions

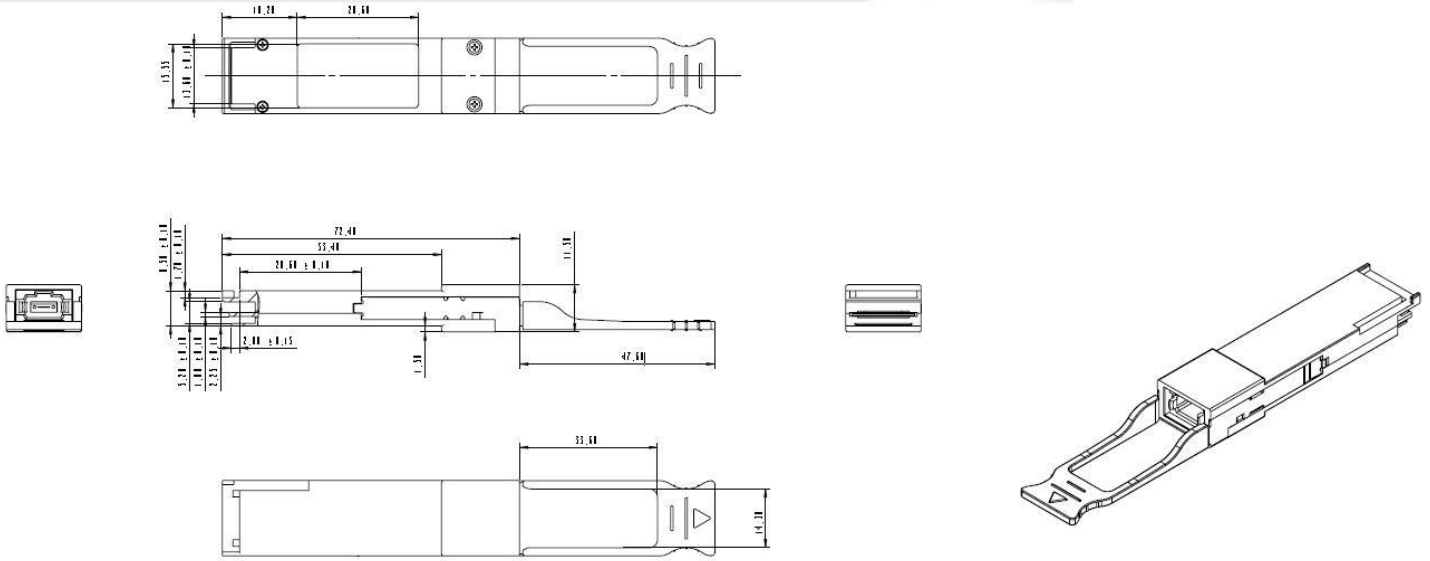

Attention: To minimize MPO connection induced reflections, an MPO receptacle with 8-degree angled end-face is utilized for this product. A male MPO connector with 8-degree end-face should be used with this product as illustrated in Figure below.

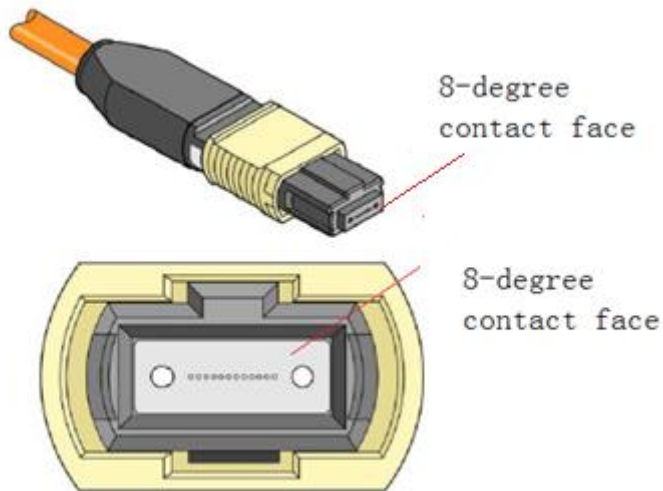

ESD

This transceiver is specified as ESD threshold 1kV for SFI pins and 2kV for all other electrical input pins, tested per MIL-STD-883, Method 3015.4 /JESD22-A114-A (HBM). However, normal ESD precautions are still required during the handling of this module. This transceiver is shipped in ESD protective packaging. It should be removed from the packaging and handled only in an ESD protected environment.

Laser Safety

This is a Class 1 Laser Product according to IEC 60825-1:2007. This product complies with 21 CFR 1040.10 and 1040.11 except for deviations pursuant to Laser Notice No. 50, dated (June 24, 2007).

Pin Assignment and Description

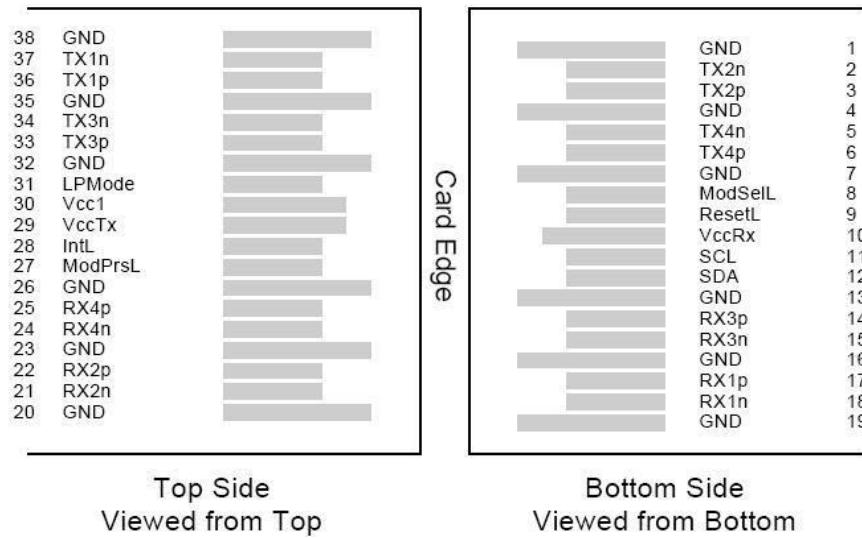

ModSelL Pin

The ModSelL is an input pin. When held low by the host, the module responds to 2-wire serial communication commands. The ModSelL allows the use of multiple QSFP modules on a single 2-wire interface bus. When the ModSelL is "High", the module will not respond to any 2-wire interface communication from the host. ModSelL has an internal pull-up in the module.

ResetL Pin

Reset. LPMode_Reset has an internal pull-up in the module. A low level on the ResetL pin for longer than the minimum pulse length (t_Reset_init) initiates a complete module reset, returning all user module settings to their default state. Module Reset Assert Time (t_init) starts on the rising edge after the low level on the ResetL pin is released. During the execution of a reset (t_init) the host shall disregard all status bits until the module indicates a completion of the reset interrupt. The module indicates this by posting an IntL signal with the Data_Not_Ready bit negated. Note that on power up (including hot insertion) the module will post this completion of reset interrupt without requiring a reset.

LPMode Pin

Rayoptek PSM IR4operate in the low power mode (less than 1.5 W power consumption) This pin active high will decrease power consumption to less than 1W.

ModPrsL Pin

ModPrsL is pulled up to Vcc on the host board and grounded in the module. The ModPrsL is asserted "Low" when the module is inserted and deasserted "High" when the module is physically absent from the host connector.

IntL Pin

IntL is an output pin. When "Low", it indicates a possible module operational fault or a status critical to the host system. The host identifies the source of the interrupt by using the 2-wire serial interface. The IntL pin is an open collector output and must be pulled up to Vcc on the host board.

Pin Assignment

PIN #	Logic	Symbol	Description	Notes
1		GND	Ground	1
2	CML-I	Tx2n	Transmitter Inverted Data Input	
3	CML-I	Tx2p	Transmitter Non-Inverted Data output	
4		GND	Ground	1

5	CML-I	Tx4n	Transmitter Inverted Data Input	
6	CML-I	Tx4p	Transmitter Non-Inverted Data output	
7		GND	Ground	1
8	LVTTLL-I	ModSelL	Module Select	
9	LVTTLL-I	ResetL	Module Reset	
10		VccRx	+3.3V Power Supply Receiver	2
11	LVCNOS-I/O	SCL	2-Wire Serial Interface Clock	
12	LVCNOS-I/O	SDA	2-Wire Serial Interface Data	
13		GND	Ground	
14	CML-O	Rx3p	Receiver Non-Inverted Data Output	
15	CML-O	Rx3n	Receiver Inverted Data Output	
16		GND	Ground	1
17	CML-O	Rx1p	Receiver Non-Inverted Data Output	
18	CML-O	Rx1n	Receiver Inverted Data Output	
19		GND	Ground	1
20		GND	Ground	1
21	CML-O	Rx2n	Receiver Inverted Data Output	
22	CML-O	Rx2p	Receiver Non-Inverted Data Output	
23		GND	Ground	1
24	CML-O	Rx4n	Receiver Inverted Data Output	1
25	CML-O	Rx4p	Receiver Non-Inverted Data Output	
26		GND	Ground	1
27	LVTTTL-O	ModPrsL	Module Present	
28	LVTTTL-O	IntL	Interrupt	
29		VccTx	+3.3 V Power Supply transmitter	2
30		Vcc1	+3.3 V Power Supply	2
31	LVTTTL-I	LPMode	Low Power Mode	
32		GND	Ground	1
33	CML-I	Tx3p	Transmitter Non-Inverted Data Input	
34	CML-I	Tx3n	Transmitter Inverted Data Output	
35		GND	Ground	1
36	CML-I	Tx1p	Transmitter Non-Inverted Data Input	
37	CML-I	Tx1n	Transmitter Inverted Data Output	
38		GND	Ground	1

Notes:

1. Module circuit ground is isolated from module chassis ground within the module. GND is the symbol for signal and supply (power) common for QSFP modules.
2. The connector pins are each rated for a maximum current of 500mA.

Wuhan RayOptek CO.,Ltd

Headquarter

Address:G3-201, New Energy Building, No.999 Gao Xin Road, Wuhan, Hubei, China

Tel:+86-27-87106345

Email:sales@rayoptek.com